



Installation Manual

TerraGen Environmental Group

120 Parsons Road

Alliston, Ontario, L9R 1E8

705-435-7373

Version: 13/11/2023

Table of Contents

1. General.....	2
2. Material Receiving	2
3. Tools	3
4. System Components	4
5. Annual Maintenance Activities	5
6. Installation of System.....	6
STEP 1: Install Anchors.....	6
STEP 2: Install Rails.....	6
STEP 3: Install End Clamps	7
STEP 4: Install Mid Clamps	7
STEP 5: Splicing	8
7. Table 1: ST-AK 19/66 Rail Span Chart	9
Appendix A: Bonding & Grounding.....	10
Appendix B: MLPE Mounting	11

1. General

The TGP System is designed to be installed on a sloped roof for an array of any size, provided the guidelines within this manual and any other applicable codes and standards are followed.

It is a rail-based design intended to secure 2-8 modules per rail, with continuity through splicing. The system can be installed in landscape or portrait orientation for PV modules up to 45" X 90", provided the project specific design has been done accordingly and the module manufacturer guidelines are followed.

To ensure proper installation and prevent a void of your warranty, the installation manual and the project specific documentation must be followed.

In unique or custom cases where alternative components or design is required, the project specific documentation will supersede the installation manual where there is insufficient or conflicting information.

2. Material Receiving

A detailed bill of lading will be sent with the shipment of racking. The receiver must confirm that all parts received are according to the detailed Bill of Lading and Packing Slip. Any damage must be noted on the bill of lading upon receipt. Any discrepancies must be reported within 2 business days. Otherwise, all claims will be invalid. If there are any damaged parts or rails, please provide a photo as well as documenting it on the Bill of Lading.

3. Tools

Tools:

1. Drill with torque limiter OR torque wrench
2. 13mm deep socket
3. 13mm combination wrench

NOTE: Accessories may require additional tools

Torque Settings Required:





12 ft-lbs (16 N-m): End clamp, mid clamp, angle brackets

Miscellaneous:

1. Onsite cutting availability
2. Measuring tape
3. Paint marker (for torque marking)
4. String and/or spray paint (for alignment)

- **Use of impact tools when installing clamps and hardware will cause galling (seizing of SS hardware). TerraGen will not free issue components damaged from use of impact tools.**
- **All fasteners must be torque marked after applying the required torque.**

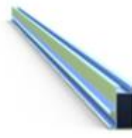
4. System Components

1 	2 	3 	4 
End Clamp	Mid Clamp w/Bonding Washer	Splice 1966 (Bonding Integrated)	Top Rail
5 	6 		
Angle Bracket & T-Bolt (M8) & Nut	Small Angle Bracket & T-Bolt (M8) & Nut		

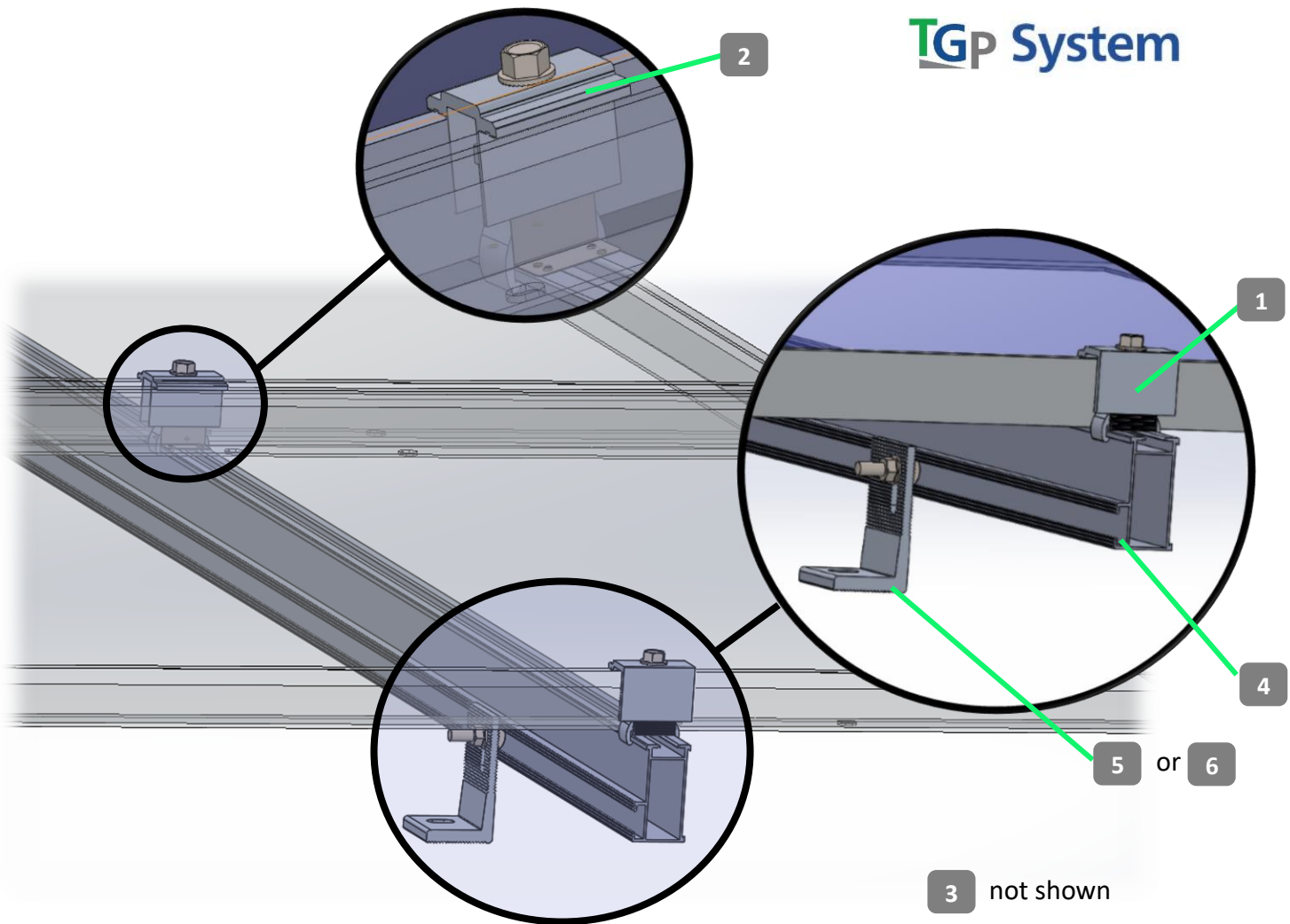

5. Annual Maintenance Activities

The activities described below for the maintenance of the solar racking provided by TerraGen must be performed a minimum of every 12 months from the date of installation up until the system has been decommissioned. Records with images of the inspection must be recorded and kept.

- Perform a visual inspection of the system to check all components for any signs of defect. Any components showing signs of damage that compromise safety shall be replaced immediately.
 - Check for any deformation, penetrating corrosion, or other noticeable defects in the components.
 - Inspect roofing condition around the contact points with the roof and that the system has not moved over time. Ensure appropriate roof protection is still secured appropriately in place.
 - Modules are seated correctly and secured.
- Check all hardware for specified torque or torque marks. Any loose components or fasteners shall be re-tightened in accordance with the installation instructions.

6. Installation of System

Module Clamping Green Zone

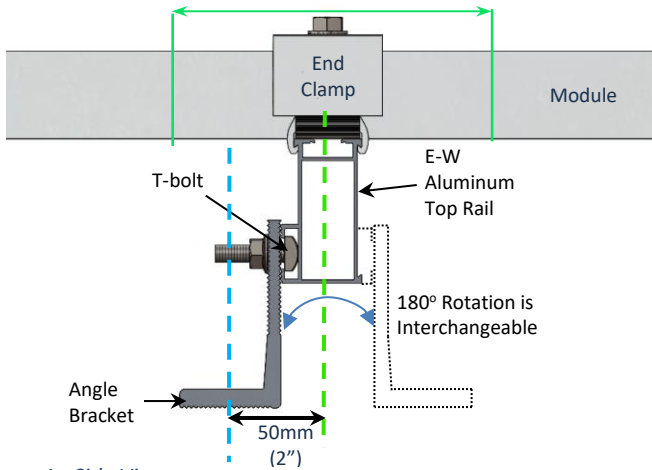

Figure 1 - Side View

STEP 1: Install Anchors – Install anchors as per the anchor’s installation manual.

- a) For the first line of anchors above the bottom edge, add 50mm (2”) to the green zone distance to account for the offset of the anchor (See Figure 1, & Line 1. of Figure 2).
- b) In the absence of a construction package, common practice is to stagger the anchors to distribute the load onto different rafters with reference to the span chart in Section 7.

TerraGen does not supply warranty protection for your selected anchor and standoff device.

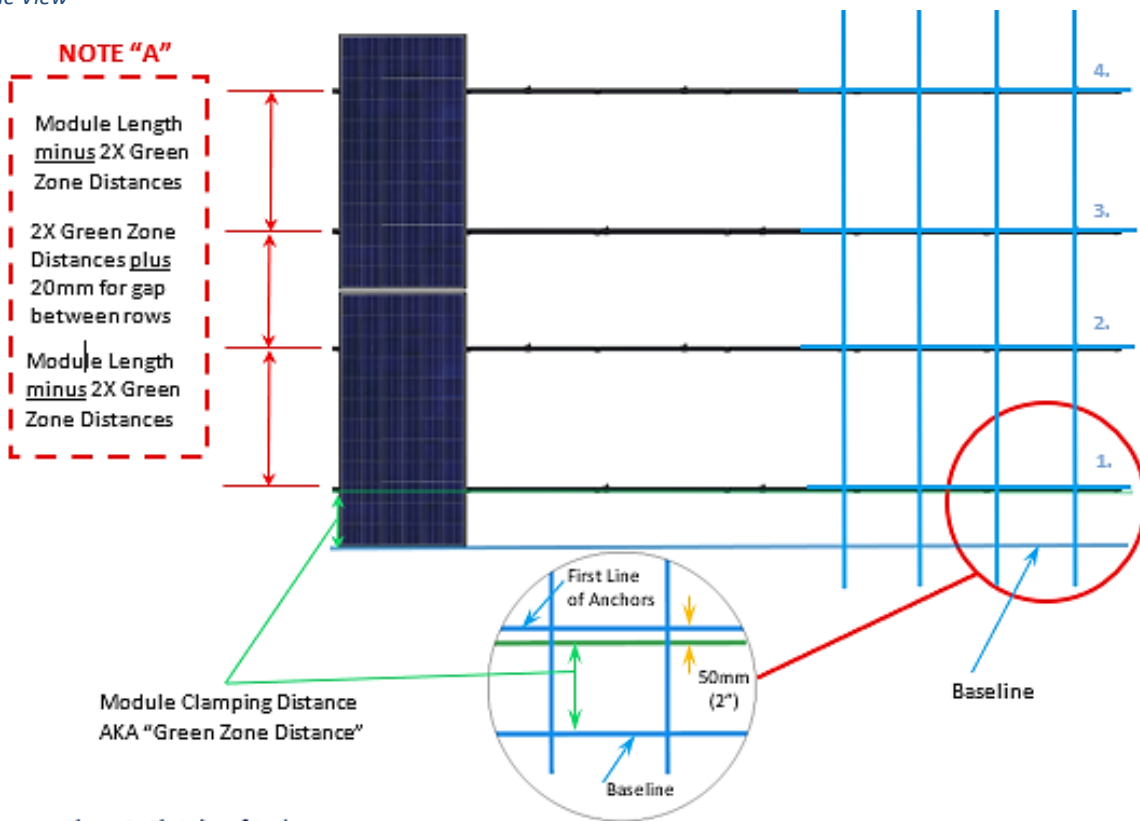

Figure 2 - First Line of Anchors

STEP 2: Install Rails – Ensure that the groove on the end of the T-bolt is perpendicular to the rail direction. See Figure 3. Tighten to 12 ft-lbs.

If top rails must be spliced together, see [STEP 5](#).

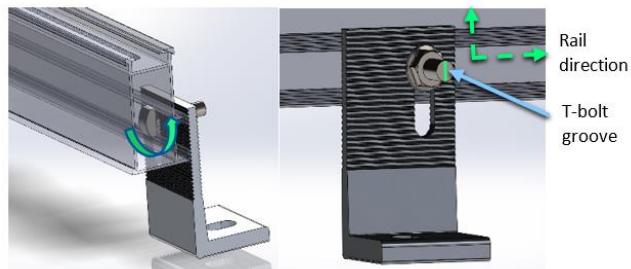

Figure 3 - T-bolt Engagement

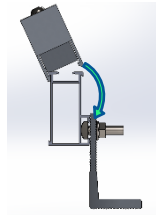

Figure 4 - Snap on end clamp

STEP 3: Install End Clamps – Tighten both end clamps at a minimum of 2 inches* away from the edge of E-W top rail. Ensure that the clamp is at the correct green zone distance.

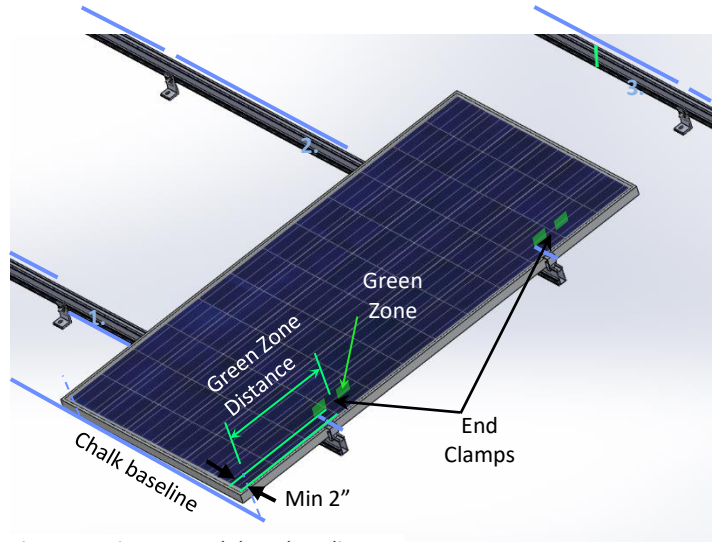

Figure 5 - Line up module to baseline

Torque: 12 ft-lbs (16.3 N-m)

STEP 4: Install Mid Clamps – Click mid clamp over bonding washer. Slide bonding washer under first module while placing top lip of mid clamp over the module frame. Similarly, place adjacent module. Tighten mid clamp with 13mm socket wrench. **Torque: 12 ft-lbs (16.3 N-m)**

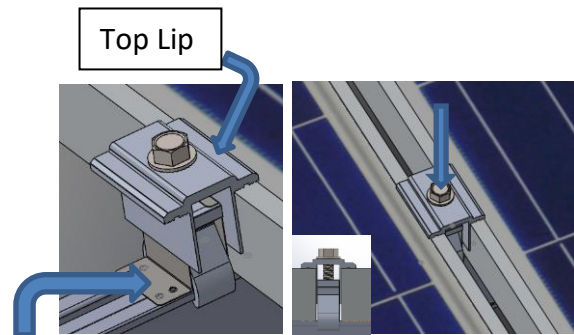
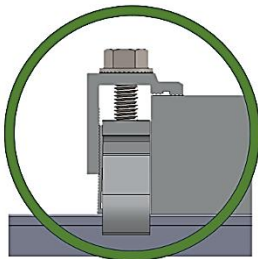
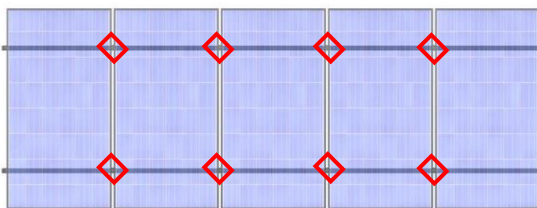
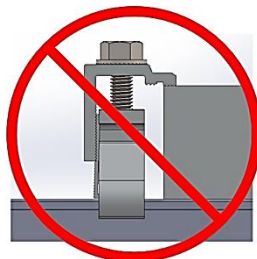

Figure 6 – Install mid clamp and bonding washer

Note that the bonding washer is not used with an end clamp. Bonding washers are installed on every mid clamp as shown below.



CORRECT - CLAMP AGAINST FRAME



INCORRECT – LARGE GAP BETWEEN CLAMP AND FRAME

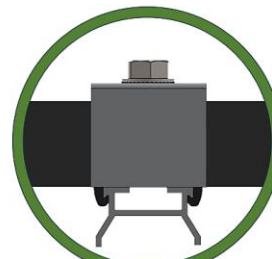

CORRECT - BOTH SIDES ENGAGED



INCORRECT – NOT ENGAGED / ANGLED

PRESS CLAMP TO FRAME PRIOR TO TORQUING

MOVE CLAMP SIDE TO SIDE TO ENSURE CLAMP CLICKS IN PLACE

STEP 5: Splicing – When required, the top rails get spliced together with a bonding integrated splice bar. Ensure that the top rail is stopped by screw head and that the bonding clip is engaged with the aluminum from both rails. Leave a 0.4” to 0.75” gap between Top rails to ensure proper bonding.

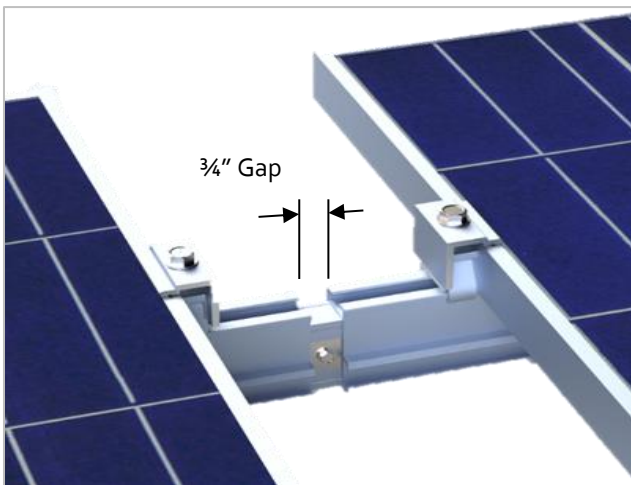
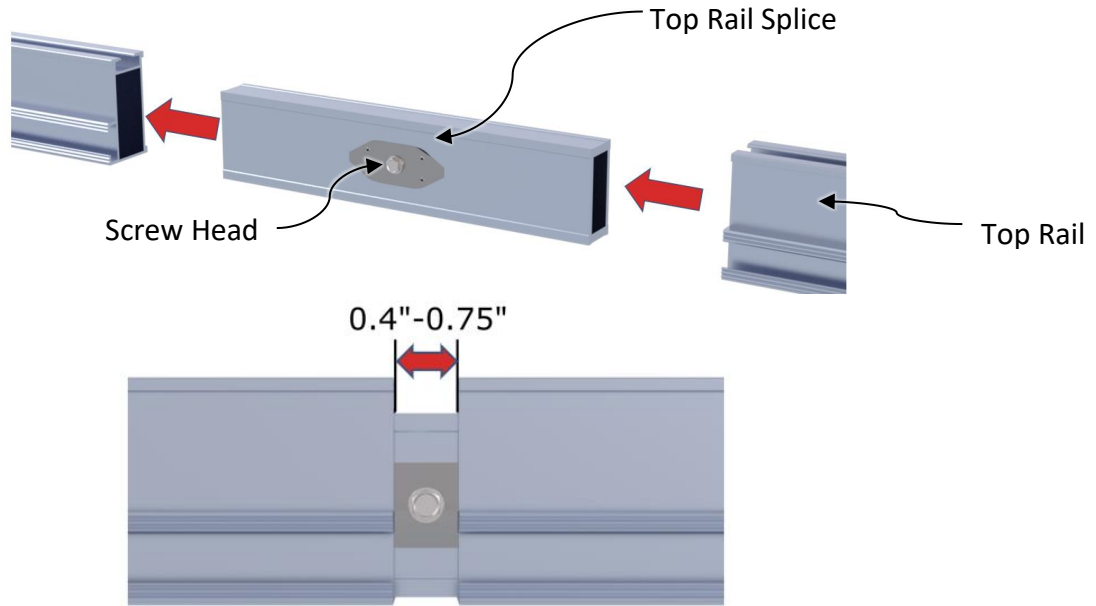

In the case that a thermal break must be made, a gap of $\frac{3}{4}$ " between the rails must be maintained. Panels may not go over a thermal break. They must end with an end clamp on either side as shown, below. Refer to the construction package for the location of the thermal breaks. If no construction package is provided, 40' should not be exceeded.

7. Table 1: ST-AK 19/66 Rail Span Chart

If no project specific design has been done, refer to the following span chart.

WIND EXPOSURE	WIND SPEED (3-SEC GUST)	SNOW LOAD (POUND PER SQUARE FEET)						NOTES (See note below for this row)
		0 psf	10 psf	20 psf	30 psf	40 psf	50 psf	
CATEGORY B	85 MPH	7' - 10"	7' - 0"	6' - 1"	5' - 5"	4' - 9"	3' - 11"	
	90 MPH	7' - 6"	6' - 10"	5' - 11"	5' - 4"	4' - 8"	3' - 11"	
	95 MPH	7' - 2"	6' - 8"	5' - 10"	5' - 2"	4' - 6"	3' - 11"	
	100 MPH	6' - 10"	6' - 5"	5' - 8"	5' - 1"	4' - 5"	3' - 9"	
	110 MPH	6' - 3"	6' - 1"	5' - 5"	4' - 10"	4' - 1"	3' - 7"	
	120 MPH	5' - 10"	5' - 9"	5' - 2"	4' - 6"	3' - 10"	3' - 5"	
	130 MPH	5' - 5"	5' - 5"	4' - 11"	4' - 2"	3' - 7"	3' - 2"	
	140 MPH	5' - 1"	5' - 1"	4' - 6"	3' - 10"	3' - 5"	3' - 0"	
150 MPH	5' - 8"	5' - 8"	5' - 5"	5' - 1"	4' - 6"	4' - 1"	See note h	
CATEGORY C	85 MPH	6' - 11"	6' - 5"	5' - 9"	5' - 2"	4' - 5"	3' - 10"	
	90 MPH	6' - 7"	6' - 4"	5' - 7"	5' - 0"	4' - 3"	3' - 8"	
	95 MPH	6' - 4"	6' - 1"	5' - 5"	4' - 10"	4' - 1"	3' - 7"	
	100 MPH	6' - 0"	5' - 11"	5' - 3"	4' - 8"	4' - 0"	3' - 6"	
	110 MPH	5' - 6"	5' - 6"	5' - 0"	4' - 3"	3' - 8"	3' - 3"	
	120 MPH	5' - 1"	5' - 1"	4' - 6"	3' - 11"	3' - 5"	3' - 0"	
	130 MPH	5' - 8"	5' - 8"	5' - 5"	5' - 1"	4' - 6"	4' - 1"	See note h
	140 MPH	5' - 3"	5' - 3"	5' - 2"	4' - 8"	4' - 2"	3' - 9"	See note h
	150 MPH	4' - 10"	4' - 10"	4' - 10"	4' - 4"	3' - 10"	3' - 6"	

This table does not include roof capacity check or standoff connection check.

- a. Installer to check lag screw pull-out capacity or roof connection and roof joist capacity.
- b. If building mean roof height exceeds 24 feet, project specific design is required.
- c. Maximum roof slope is 45 degrees.
- d. If solar module dimensions exceed 79"x 40", project specific design is required.
- e. Maximum end cantilever span is 21".

Appendix A: Bonding & Grounding

The system has been evaluated/certified for Grounding/Bonding, and conforms to UL 2703. Refer to 'Module Listings' document for modules that have been certified to LTR AE-001-2012 and UL 2703.

Connection 1: Module to Top Rail

Mid-clamps with bonding washers bond rails to module frames with teeth piercing the anodized surface of the module.



Connection 2: Top Rail to Top Rail

In cases where two or more rails may need to be spliced together, top rails are spliced through a sliding splice which consists of a bonding clip that pierces the surface of the aluminum rails.

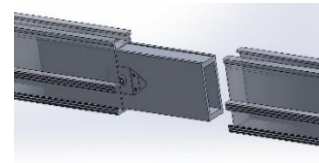

Connection 3: Grounding Each Row

IlSCO SGB-4 or other UL 467 listed Grounding Device (supplied by others) is used to ground the system. Provided the previously mentioned connections all apply; each individual row needs to be grounded once. Location for grounding device is often the excess end of a top rail.

Appendix B: MLPE Mounting

T-Bolt assembly is available upon request from TerraGen to mount MLPE (microinverter or optimizer) into the channel of TerraGen rails. Ensure that guidelines from the MLPE installation manual are followed.

